



# **NL104-HL Hardware Design**

**GPS+Glonass Module**

**Rev. NL104-HL\_Hardware\_Design\_V2.2 Date: 2022-04-20**

## Contents

1	Description.....	4
1.1.	Key Features.....	4
1.2.	Block Diagram.....	5
2	Application.....	5
2.1.	Pin Assignment.....	5
2.2.	Pin Definition.....	6
2.3.	Power Supply.....	7
2.4.	UART Interface.....	9
2.5.	PPS VS. NMEA.....	11
3	Antenna Interfaces.....	12
3.1.	PCB Design Guide.....	12
3.2.	External Active Antenna.....	12
4	Electrical, Reliability and Radio Characteristics.....	13
4.1.	Absolute Maximum Ratings.....	13
4.2.	Operating Conditions.....	14
4.3.	Current Consumption.....	14
4.4.	Electrostatic Discharge.....	15
5	Mechanical Dimensions.....	15
6	Manufacturing, Packaging and Ordering Information.....	16
6.1.	Assembly and Soldering.....	16
6.2.	Moisture Sensitivity.....	16
6.3.	ESD Protection.....	17
6.4.	Tape and Reel Packaging.....	17
7	Appendix References.....	18

**General Description**

The NL104-HL is a complete GPS+Glonass engine module that features super sensitivity, ultra low power and small form factor. The GNSS signal is applied to the antenna input of module, and a complete serial data message with position, velocity and time information is presented at the serial interface with NMEA protocol or custom protocol. Its -162dBm tracking sensitivity extends positioning coverage into place like urban canyons and dense foliage environment where the GNSS was not possible before. The small form factor and low power consumption make the module easy to integrate into portable device like DVR, UVA, Car trackers applications

Main chip	HD8021
Track sensitivity	-162dBm
Time to First Fix	Extremely fast TTFF at low signal level
Built in high LNA	YES
Power consumption	Average 60mA@3.3V
Protocol	NMEA-0183 compliant protocol
Operating temperature	-40 to 85°C
Operating voltage	2.8V to 3.6V
Module type	SMD
Size	10.1x9.7x2.2mm
Certification	RoHS compliant(Lead-free)

**Table 1:** General Description

# 1 Description

## 1.1. Key Features

Parameter Specification	Specification
Power Supply	Supply voltage: 2.8V~3.6V Typical: 3.3V
Power Consumption	Acquisition: 60mA @VCC=VBAT=3.3V Tracking: 45mA @VCC=VBAT=3.3V Backup: 25uA @VBAT=3.3V
Receiver Type	72 search channels GPS&&QZSS L1 1575.42MHz C/A , GLONASS L1 1602MHz SBAS: WAAS, EGNOS, MSAS, GAGAN
Sensitivity	Tracking: -162dBm Re-acquisition: -156dBm Acquisition: -147dBm
TTF	Cold start: 35s typ @-130dBm Warm start: 30s typ @-130dBm Hot start: 1s typ @-130dBm
Horizontal Position Accuracy (Autonomous)	<2.5m CEP @-130 dBm
Update Rate	1Hz
Accuracy of 1PPS Signal	Typical accuracy: ±10ns Time pulse width: 100ms
Acceleration Accuracy	Without aid: 0.1m/s <sup>2</sup>
Dynamic Performance	Maximum altitude: 18,000m Maximum velocity: 515m/s Acceleration: 4G
UART Port	UART Port: TXD and RXD Supports baud rate from 4800bps to 115200bps, 9600bps By default. UART port is used for NMEA output, Huada proprietary commands
Temperature Range	Normal operation: -40°C ~ +85°C Storage temperature: -45°C ~ +125°C
Physical Characteristics	Size: 10.1±0.15 x 9.7±0.15 x 2.2±0.1mm Weight: Approx. 0.41g

**Table 2:** Key Features

### 1.2. Block Diagram

The following figure shows a block diagram of NL104-HL module. It consists of a single chip GNSS IC which includes the RF part and Baseband part, a LNA, a SAW filter, a TCXO, a crystal oscillator.

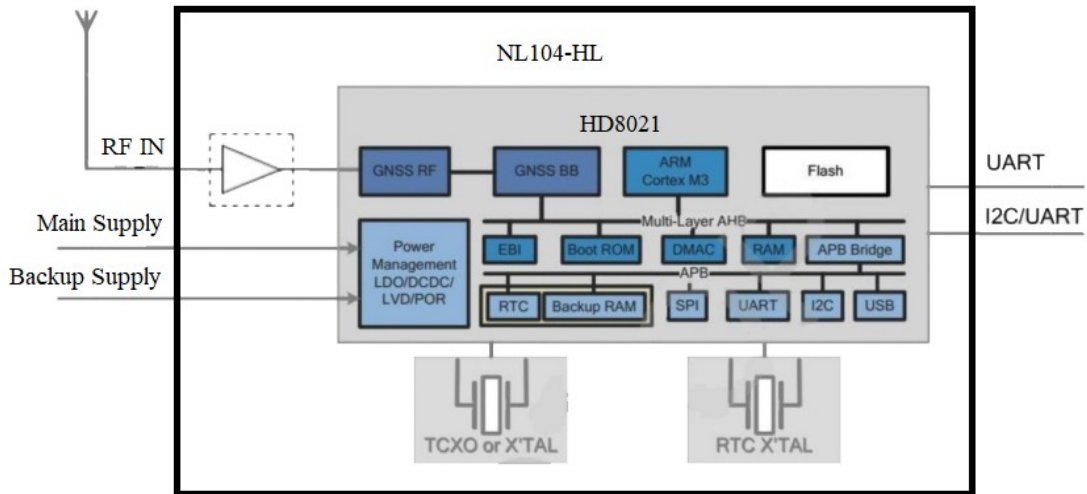

Figure 1: Block Diagram

## 2 Application

The module is equipped with a 18-pin SMT pad that connects to your application platform. Sub-interfaces included in the pad are described in details in the following chapters.

### 2.1. Pin Assignment



Figure 2: Pin Assignment

## 2.2. Pin Definition

Pin Name	Pin No.	I/O	Description	DC Characteristics	Comment
<b>Power Supply</b>					
VCC	8	I	Main power supply	V <sub>max</sub> =3.6V V <sub>min</sub> =2.8V V <sub>nom</sub> =3.3V	Supply current not less than 100mA.
VBAT	6	I	Backup power supply	V <sub>max</sub> =3.6V V <sub>min</sub> =1.5V V <sub>nom</sub> =3.3V	Supply power for RTC domain. The VBAT pin can be directly supplied power by battery or connect it to VCC.
GND	1,10,12	G	Ground		Assure a good GND connection to all GND pins of the module, preferably with a large ground plane
<b>Other Interfaces</b>					
PPS	4	O	One pulse per second	V <sub>OLmin</sub> =-0.3V V <sub>OLmax</sub> =0.4V V <sub>OHmin</sub> =2.4V V <sub>OHmax</sub> =3.1V	Synchronized at rising edge, the pulse width is 100ms. If unused, keep this pin open.
<b>UART Port</b>					
RXD	3	I	Receive data	V <sub>ILmin</sub> =-0.3V V <sub>ILmax</sub> =0.8V V <sub>IHmin</sub> =2.0V V <sub>IHmax</sub> =3.6V	
TXD	2	O	Transmit data	V <sub>OLmin</sub> =-0.3V V <sub>OLmax</sub> =0.4V V <sub>OHmin</sub> =2.4V V <sub>OHmax</sub> =3.1V	
<b>RF Interface</b>					
RF_IN	11	I	External active antenna RF input		Characteristic impedance of 50Ω
VCC_RF	9	O	Active antenna power output	V <sub>nom</sub> =3.3V	Output Voltage RF section. VCC_RF can be selected according to the type of antenna

**Table 3:** Pin Definition

### 2.3. Power Supply

VCC pin supplies power for BB, RF, I/O, LNA, Antenna. The load current of VCC varies according to the VCC level, processor load, the number of tracked satellites and the rate of satellite re-acquisition. Using external active antenna will consume additional 11mA from our module. So it is important to supply sufficient current and make the power clean and stable. VCC supply ripple voltage should meet the requirement: 54mV (RMS) max @f=0...3MHz and 15mV (RMS) max@f >3MHz. You should choose the LDO without built-in output high-speed discharge function to keep long output voltage drop-down period. The decouple combination of 10uF and 100nF capacitor is recommended nearby VCC pin.

The VBAT pin supplies power for RTC domain. It should be valid when power on the module. The voltage of RTC domain ranges from 1.8V to 3.6V. In order to achieve a better TTFF, RTC domain should be valid all the time. It can supply power for SRAM memory in RTC domain which contains all the necessary GPS&Beidou information for quick start-up and a small amount of user configuration variables. The module's internal power construction is shown as below.

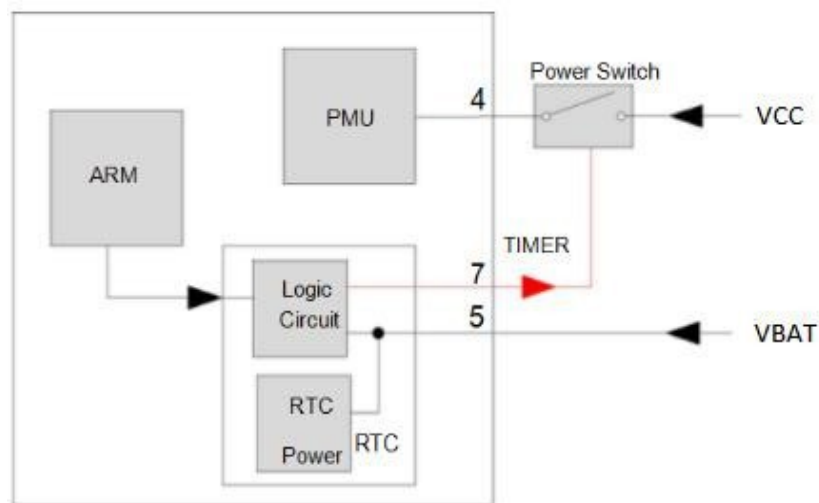

**Figure 3: Internal Power Construction**

VCC supplies power for PMU, and VBAT supplies power for RTC domain. TIMER signal highlighted in red in the following figure belongs to RTC domain and can be used to control the power switch on/off

The simplest power circuit for LN104-HL module is 3.3V power source connected to VCC pin and VBAT pin of the module directly. In this case, once you powered on the module, the full cold start will be implemented.

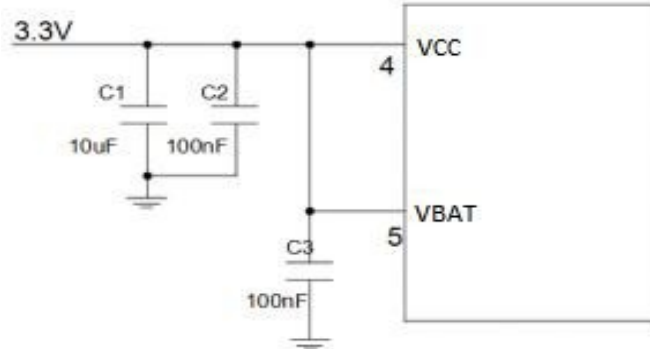
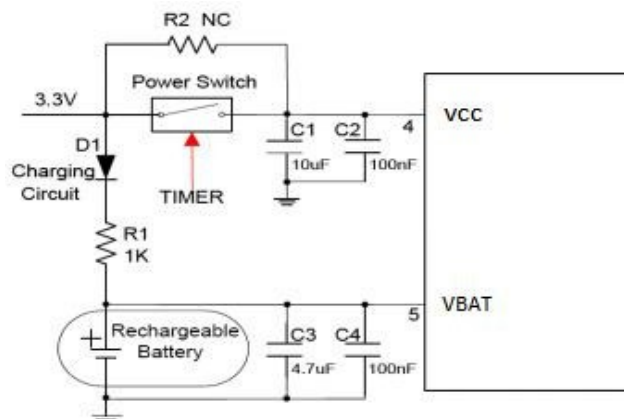

**Figure 4:** Reference Circuit for Power Supply

If your power supply circuit adopts the design mentioned above, LN104-HL module does not support backup mode.

The other way is feeding VBAT through a backup battery directly. The module will enter into backup mode when power source (3.3V) is cut off. Furthermore, it is necessary to add an external charging circuit for rechargeable battery. The detailed schematic (mount R2 with 0R to replace Power switch) is shown as there is no charge source when power source (3.3V) is cut off. MS621FE FL11E from Seiko is recommended. The consumption of VBAT is as low as 7µA in backup mode.

The schematic with power supply circuit is shown as below. As power source (3.3V) is always valid and the battery is charged continuously, the capacity of the battery can be small. The detailed schematic for power switch circuit is shown in **Figure 5**.



**Figure 5:** Reference Charging Circuit for Chargeable Battery



VCC does not supply power for RTC domain in LN104-HL module, so the VBAT pin must be powered externally. Furthermore, it is strongly recommended to supply power to VBAT through a backup battery, which can ensure LN104-HL module improves TTFF after next restart. For details about TTFF.

#### 2.4. UART Interface

The module provides one universal asynchronous receiver& transmitter serial port. The module is designed as DCE (Data Communication Equipment), following the traditional DCE-DTE (Data Terminal Equipment) connection. The module and the client (DTE) are connected through the signals shown in the following figure. It supports data baud-rate from 4800bps to 115200bps.

##### UART port:

TXD: Send data to the RXD1 signal line of DTE.

RXD Receive data from the TXD1 signal line of DTE

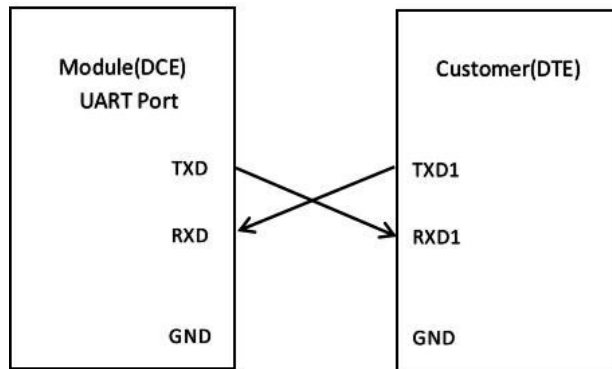

**Figure 6:** Connection of Serial Interfaces

##### This UART port has the following features:

- UART port can be used for NMEA output and proprietary commands input.
- The default output NMEA type setting is RMC, GGA, GSA, GSV, GLL, VTG
- UART port supports the following data rates:
- 4800, 9600, 14400, 19200, 38400, 57600, 115200bps.
- The default setting is 9600bps, 8 bits, no parity bit, 1 stop bit.
- Hardware flow control and synchronous operation are not supported.

The module supports the commonly used commands in configuration, The following table describes some of the parameters of the UART port configuration command, The Module power up initialization requires 300ms, Please send the sixteen system from CPU via serial port.

Settings	Command HEX
<b>Warm start</b>	F1 D9 06 40 01 00 02 49 23
<b>Warm start</b>	F1 D9 06 40 01 00 02 49 23
<b>Hot start</b>	F1 D9 06 40 01 00 03 4A 24
<b>Reset</b>	F1 D9 06 40 01 00 00 47 21
<b>GPS Stop</b>	F1 D9 06 40 01 00 11 58 32
<b>GPS Start</b>	F1 D9 06 40 01 00 11 58 32
<b>Baud rate is 4800bps</b>	F1 D9 06 00 08 00 00 00 00 00 C0 12 00 00 E0 CE
<b>Baud rate is 9600bps</b>	F1 D9 06 00 08 00 00 01 0E 33 80 25 00 00 F5 61
<b>Baud rate is 19200bps</b>	F1 D9 06 00 08 00 00 00 00 00 00 4B 00 00 59 79
<b>Baud rate is 38400bps</b>	F1 D9 06 00 08 00 00 00 00 00 00 96 00 00 A4 5A
<b>Baud rate is 57600bps</b>	F1 D9 06 00 08 00 00 00 00 00 00 E1 00 00 EF 3B
<b>Baud rate is 115200bps</b>	F1 D9 06 00 08 00 00 00 00 00 00 C2 01 00 D1 E0

**Table 4: Common instruction**

The UART port does not support the RS-232 level but only CMOS level. If the module's UART port is connected to the UART port of a computer, it is necessary to add a level shift circuit between the module and the computer. Please refer to the following figure.

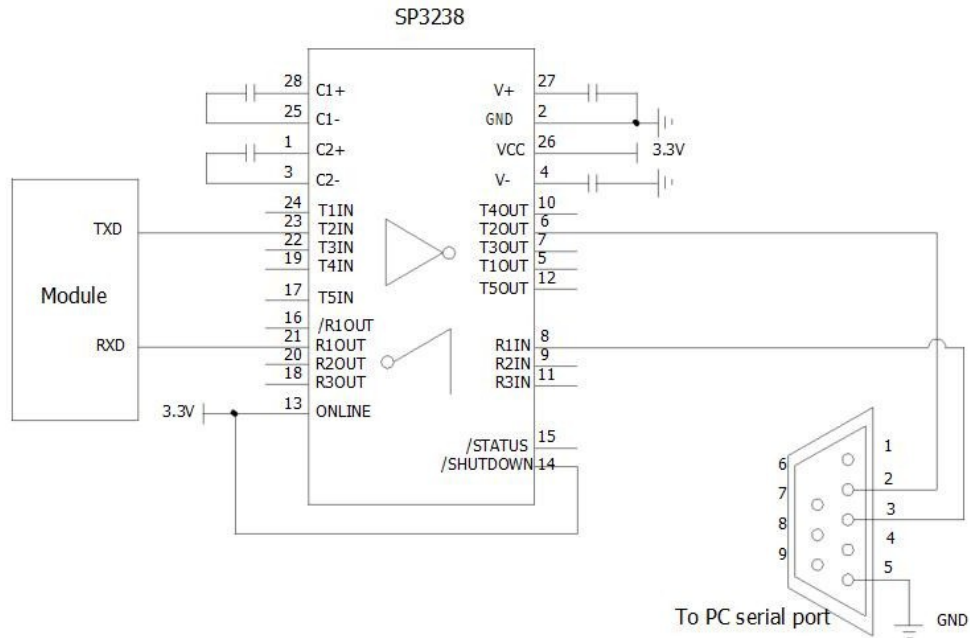

Figure 7: RS-232 Level Shift Circuit

### 2.5. PPS VS. NMEA

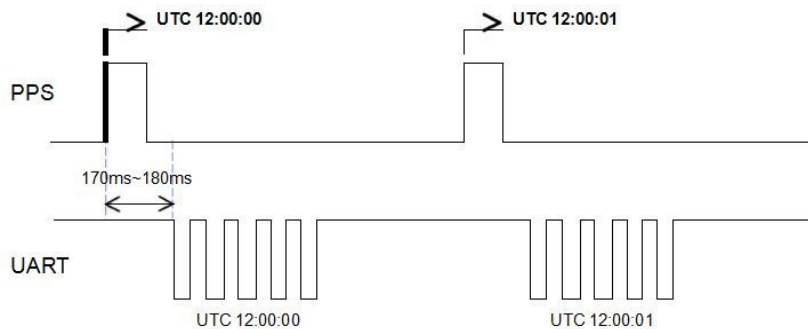

Figure 8: PPS VS. NMEA Timing

This feature only supports 1Hz NMEA output and baud rate at 14400~115200bps. At baud rate of 9600 and 4800bps, it only supports RMC NMEA sentence. Because at low baud rate, per second transmission may exceed one second if there are many NMEA sentences output.

### 3 Antenna Interfaces

#### 3.1. PCB Design Guide

The LN104-HL GPS&Beidou receiver is designed for supporting the active antenna or passive antenna connected with pin RF\_IN. The gain of active antenna should be no less than 15dB. The maximum noise figure should be no more than 2.5dB and output impedance is at 50 Ohm.

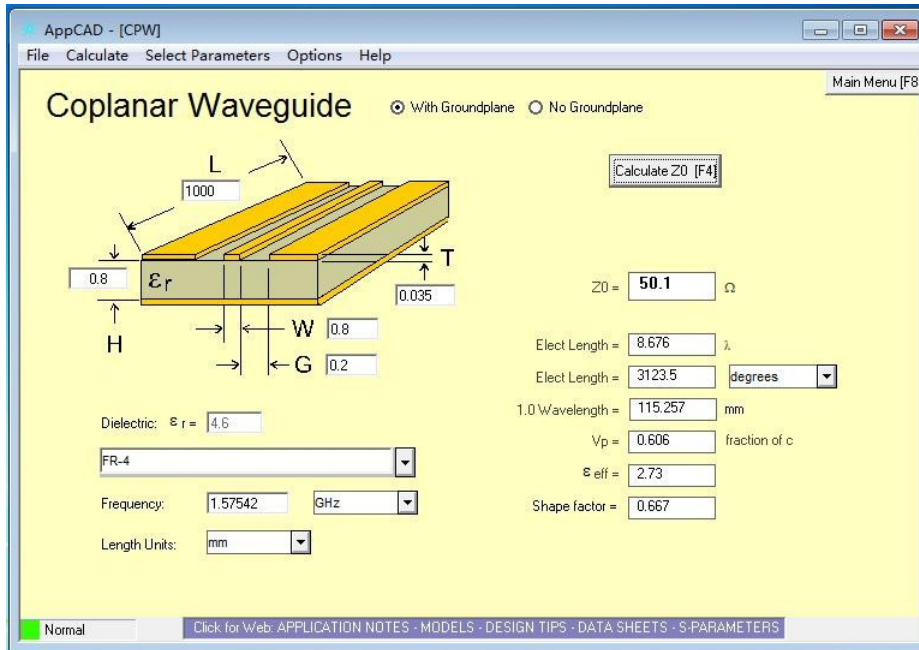

Figure 9: Antenna design requirements

#### 3.2. External Active Antenna

The following figure is a typical reference design with active antenna. In this mode, DC on the VCC\_RF pin is powered by VCC and supplies power to the external active antenna.

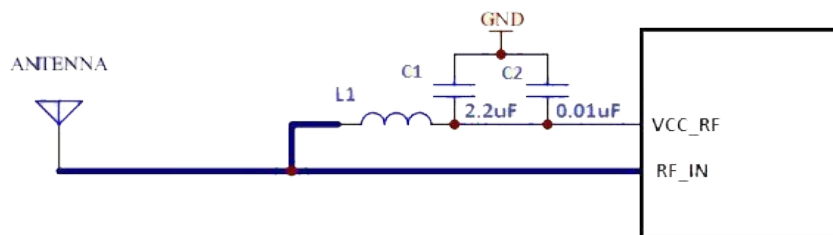

Figure 10: Reference Design for Active Antenna

C1, C2, L1 is used for power supply and filtering effect to the external active antenna, RF\_IN antenna to a circuit part (BOLD line) for high frequency microstrip line, PCB in the design of this part of the line to calculate the characteristic impedance of the high-frequency line according to the principle of high frequency wiring.

Requirements: this section of the line in the 1575.42MHz frequency characteristic impedance requirement is 50 ohm.

Antenna Type	Specification
Active Antenna	Center frequency: 1575.42MHz Band width: >5MHZ VSWR: <2 (Typ.) Polarization: RHCP or Linear Noise figure: <1.5dB Gain (antenna): >-2dBi Gain ( embedded LNA): 20dB (Typ.) Total gain: >18dBi(Typ.)

**Table 5:** Recommended Active Antenna Specification

## 4 Electrical, Reliability and Radio Characteristics

### 4.1. Absolute Maximum Ratings

Absolute maximum ratings for power supply and voltage on digital pins of the module are listed in the following table. Values within the specified boundaries by using appropriate protection diodes.

Parameter	Min.	Max.	Unit
Power Supply Voltage (VCC)	-0.3	3.6	V
Backup Battery Voltage (VBAT)	-0.3	3.6	V
Input Voltage at Digital Pins	-0.3	3.6	V
Input Power at RF_IN		15	dBm
Storage Temperature	-45	125	°C

**Table 6:** Absolute Maximum Ratings

Stressing the device beyond the “Absolute Maximum Ratings” may cause permanent damage. These are stress ratings only. The product is not protected against over voltage or reversed voltage. If necessary, voltage spikes exceeding the power supply voltage specification, given in table above, must be limited to values within the specified boundaries by using appropriate protection diodes.

#### 4.2. Operating Conditions

Parameter	Description	Conditions	Min.	Typ.	Max.	Unit.
VCC	Supply voltage	Voltage must stay within the min/max values, including voltage drop, ripple, and spikes	2.8	3.3	3.6	mA
IVCCP	Peak supply current	VCC=3.3V			100	mA
VBAT	VBAT Backup voltage supply		1.8	3.3	3.6	V
TOPR	Normal operating temperature		-40	25	80	°C

**Table 7: Power Supply Ratings**

- The figure IVCCP can be used to determine the maximum current capability of power supply.
- Operation beyond the "Operating Conditions" is not recommended and extended exposure beyond the "Operating Conditions" may affect the device’s reliability.

#### 4.3. Current Consumption

The values for current consumption are shown in the following table.

<i>Parameter</i>	<i>Conditions</i>	<i>Min.</i>	<i>Typ.</i>	<i>Max.</i>	<i>Unit</i>
I <sub>VCC</sub> @Acquisition	VCC=V BCKP=3.3V		60		mA
I <sub>VCC</sub> @Tracking	VCC=V BCKP=3.3V		45		mA
I <sub>VCC</sub> @Standby	VCC=V BCKP=3.3V		2.0		mA
I <sub>BCKP</sub> @Backup	VBAT=3.3V		25		uA

**Table 8: Current Consumption**

**The tracking current is tested in the following conditions:**

- In Cold Start, 10 minutes after First Fix.
- In Hot Start, 15 seconds after First Fix.

#### 4.4. Electrostatic Discharge

LN104-HL module is an ESD sensitive device. ESD protection precautions should still be emphasized. Proper ESD handling and packaging procedures must be applied throughout the processing, handling and operation of any application.

The ESD bearing capability of the module is listed in the following table. Note that you should add ESD components to module pins in particular applications.

Pin	Contact Discharge	Air Discharge
RF_IN	±5KV	±10KV
VCC	±5KV	±10KV
UART	±3KV	±6KV
Others	±2KV	±4KV

**Table 9:** ESD Endurance Table (Temperature : 25°C, Humidity: 45%)

### 5 Mechanical Dimensions

This chapter describes the mechanical dimensions of the module.

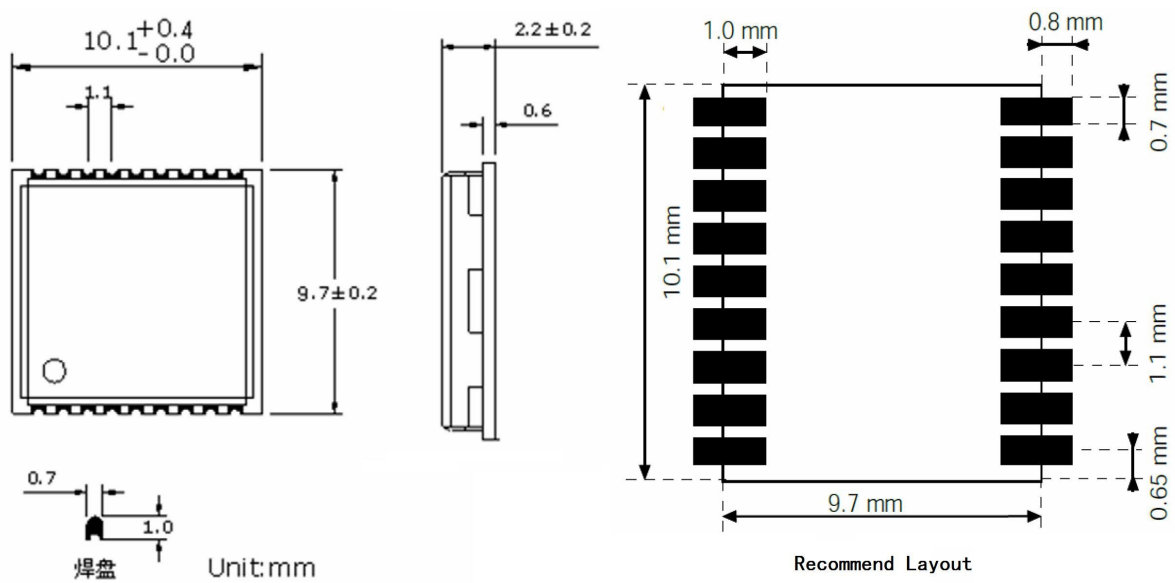

**Figure 11:** Bottom View Dimensions

## 6 Manufacturing, Packaging and Ordering Information

### 6.1. Assembly and Soldering

LN104-HL module is intended for SMT assembly and soldering in a Pb-free reflow process on the top side of the PCB. It is suggested that the minimum height of solder paste stencil is 100um to ensure sufficient solder volume. Pad openings of paste mask can be increased to ensure proper soldering and solder wetting over pads. It is suggested that the peak reflow temperature is 235~245°C (for SnAg3.0Cu0.5 alloy). The absolute maximum reflow temperature is 260 °C. To avoid damage to the module when it is repeatedly heated, it is suggested that the module should be mounted after reflow soldering for the other side of PCB has been completed. Recommended reflow soldering thermal profile is shown below:

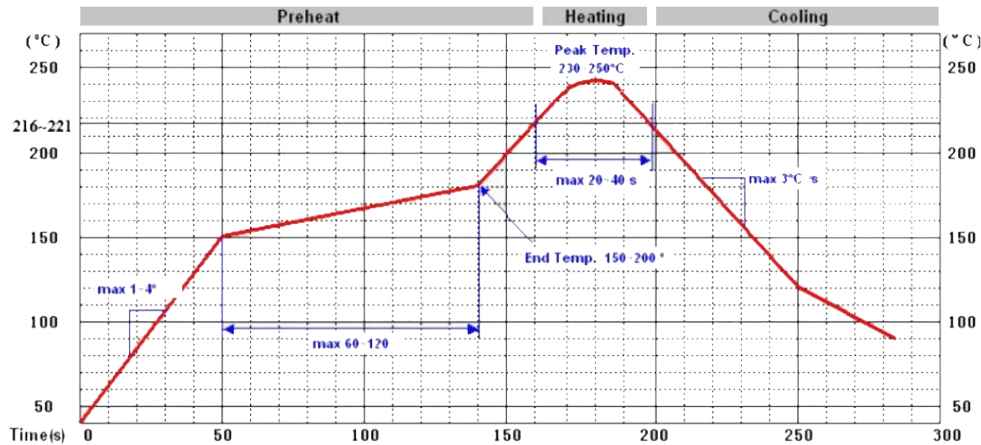

Figure 12: Recommended Reflow Soldering Thermal Profile

### 6.2. Moisture Sensitivity

LN104-HL module is sensitive to moisture. To prevent LN104-HL from permanent damage during reflow soldering, baking before reflow soldering is required in following cases:

- Humidity indicator card: One or more indicating spots are no longer blue.
- The seal is opened and the module is exposed to excessive humidity.

LN104-HL should be baked for 192 hours at temperature 40°C+5°C/-0°C and <5% RH in low-temperature containers, or 24 hours at temperature 125°C±5°C in high-temperature containers. Care should be taken that the plastic tape is not heat resistant. LN104-HL should be taken out from the tape before preheating; otherwise, the tape maybe damaged by high-temperature heating.



### 6.3. ESD Protection

LN104-HL module is sensitive to ESD and requires special precautions when handling. Particular care must be exercised when handling patch antenna, duo to the risk of electrostatic charges.

### 6.4. Tape and Reel Packaging

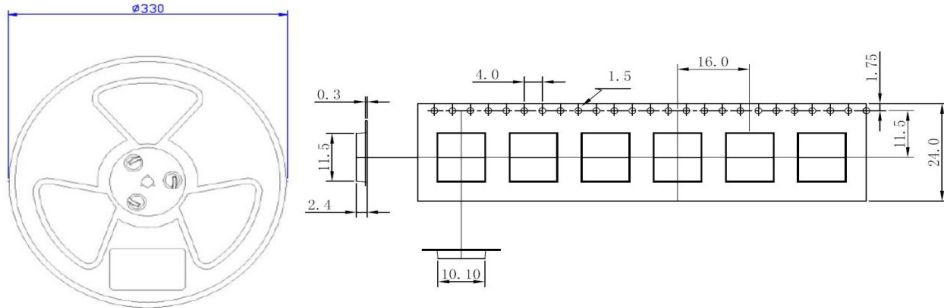

Figure 13: Tape and Reel Specifications

Unit: mm

Quantity per reel: 1500pcs

Length per reel: 16m



Figure 14: Tape and Reel Specifications

Model Name	MOQ for MP	Minimum Package: 1000pcs
LN104-HL	1500pcs	Size: 365mm × 350mm × 53mm N.W: 1.3kg G.W: 1.5kg

## 7 Appendix References

Abbreviation	Description
AGNSS	Assisted Global navigation satellite system
DGPS	Differential GPS
ESD	Electrostatic Discharge
GPS	Global Positioning System
GNSS	Global Navigation Satellite System
GGA	GNSS Fix Data
GLL	Geographic Position – Latitude/Longitude
GLONASS	Global Navigation Satellite System
GSA	GNSS DOP and Active Satellites
GSV	GNSS Satellites in View
HDOP	Horizontal Dilution of Precision
I/O	Input/Output
Kbps	Kilo Bits Per Second
LNA	Low Noise Amplifier
MSAS	Multi-Functional Satellite Augmentation System
MOQ	Minimum Order Quantity
NMEA	National Marine Electronics Association
PDOP	Position Dilution of Precision
PPS	Pulse Per Second
PRN	Pseudo Random Noise Code
QZSS	Quasi-Zenith Satellite System
RHCP	Right Hand Circular Polarization
RMC	Recommended Minimum Specific GNSS Data
SBAS	Satellite-based Augmentation System
SAW	Surface Acoustic Wave
SPDT	Single-Pole Double-Throw
TTF	Time To First Fix

Description	Description
UART	Universal Asynchronous Receiver & Transmitter
VDOP	Vertical Dilution of Precision
VTG	Course over Ground and Ground Speed, Horizontal Course and Horizontal Velocity
WAAS	Wide Area Augmentation System
Inom	Nominal Current
I <sub>max</sub>	Maximum Load Current
VOL <sub>min</sub>	Minimum Output Low Level Voltage Value
V <sub>max</sub>	Maximum Voltage Value
V <sub>nom</sub>	Nominal Voltage Value
V <sub>min</sub>	Minimum Voltage Value
VIH <sub>max</sub>	Maximum Input High Level Voltage Value
VIH <sub>min</sub>	Minimum Input High Level Voltage Value
VIL <sub>max</sub>	Maximum Input Low Level Voltage Value
VIL <sub>min</sub>	Minimum Input Low Level Voltage Value
VI <sub>max</sub>	Absolute Maximum Input Voltage Value
VI <sub>min</sub>	Absolute Minimum Input Voltage Value
VOH <sub>max</sub>	Maximum Output High Level Voltage Value
VOH <sub>min</sub>	Minimum Output High Level Voltage Value
VOL <sub>max</sub>	Maximum Output Low Level Voltage Value